

---

### Silicon NPN Phototransistor

---

#### Description

BPW16N is a silicon NPN epitaxial planar phototransistor in a miniature plastic case with flat window.

With a lead center to center spacing of 2.54mm and a package width of 2.4mm the devices are easily stackable on PC boards and assembled to arrays of unlimited size.

Due to its waterclear epoxy the device is sensitive to visible and near infrared radiation.

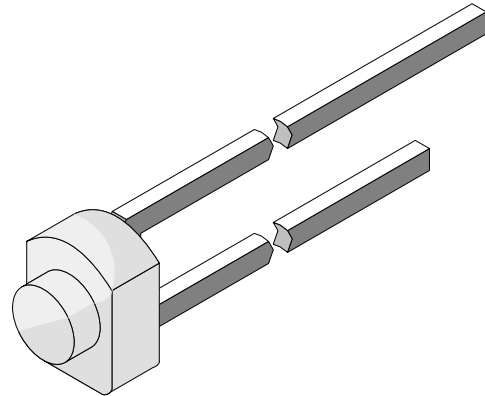

94 8638

#### Features

- Miniature T- $\frac{3}{4}$  flat clear plastic package
- Very wide viewing angle  $\phi = \pm 40^\circ$
- Suitable for 0.1" (2.54 mm) center to center spacing
- Suitable for visible and near infrared radiation
- Compatible with IR diode CQY 36 N

#### Applications

Detector in electronic control and drive circuits

### Absolute Maximum Ratings

 $T_{amb} = 25^{\circ}\text{C}$ 

Parameter	Test Conditions	Symbol	Value	Unit
Collector Emitter Voltage		$V_{CEO}$	32	V
Emitter Collector Voltage		$V_{ECO}$	5	V
Collector Current		$I_C$	50	mA
Peak Collector Current	$t_p/T = 0.5, t_p \leq 10 \text{ ms}$	$I_{CM}$	100	mA
Total Power Dissipation	$T_{amb} \leq 55^{\circ}\text{C}$	$P_{tot}$	100	mW
Junction Temperature		$T_j$	100	$^{\circ}\text{C}$
Storage Temperature Range		$T_{stg}$	-55...+100	$^{\circ}\text{C}$
Soldering Temperature	$t \leq 3 \text{ s}$	$T_{sd}$	260	$^{\circ}\text{C}$
Thermal Resistance Junction/Ambient		$R_{thJA}$	450	K/W

### Basic Characteristics

 $T_{amb} = 25^{\circ}\text{C}$ 

Parameter	Test Conditions	Symbol	Min	Typ	Max	Unit
Collector Emitter Breakdown Voltage	$I_C = 1 \text{ mA}$	$V_{(BR)CEO}$	32			V
Collector Dark Current	$V_{CE} = 20 \text{ V}, E = 0$	$I_{CEO}$		1	200	nA
Collector Emitter Capacitance	$V_{CE} = 5 \text{ V}, f = 1 \text{ MHz}, E=0$	$C_{CEO}$		8		pF
Collector Light Current	$E_e = 1 \text{ mW/cm}^2, \lambda = 950 \text{ nm}, V_{CE} = 5 \text{ V}$	$I_{ca}$	0.07	0.14		mA
Angle of Half Sensitivity		$\varphi$		$\pm 40$		deg
Wavelength of Peak Sensitivity		$\lambda_p$		825		nm
Range of Spectral Bandwidth		$\lambda_{0.5}$		620...960		nm
Collector Emitter Saturation Voltage	$E_e = 1 \text{ mW/cm}^2, \lambda = 950 \text{ nm}, I_C = 0.01 \text{ mA}$	$V_{CEsat}$			0.3	V
Turn-On Time	$V_S = 5 \text{ V}, I_C = 5 \text{ mA}, R_L = 100 \Omega$	$t_{on}$		4.8		$\mu\text{s}$
Turn-Off Time	$V_S = 5 \text{ V}, I_C = 5 \text{ mA}, R_L = 100 \Omega$	$t_{off}$		5.0		$\mu\text{s}$
Cut-Off Frequency	$V_S = 5 \text{ V}, I_C = 5 \text{ mA}, R_L = 100 \Omega$	$f_c$		120		kHz

## Typical Characteristics ( $T_{amb} = 25^{\circ}\text{C}$ unless otherwise specified)

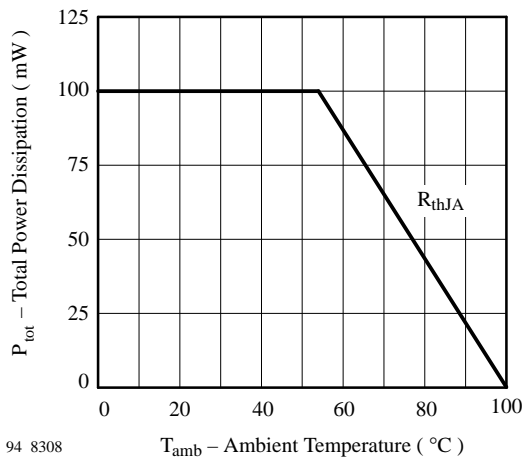

Figure 1 : Total Power Dissipation vs. Ambient Temperature

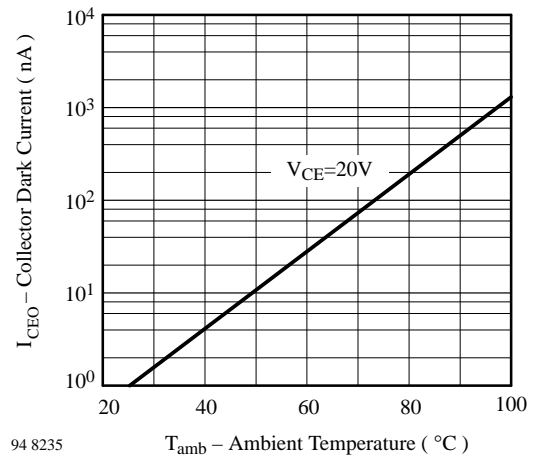

Figure 2 : Collector Dark Current vs. Ambient Temperature

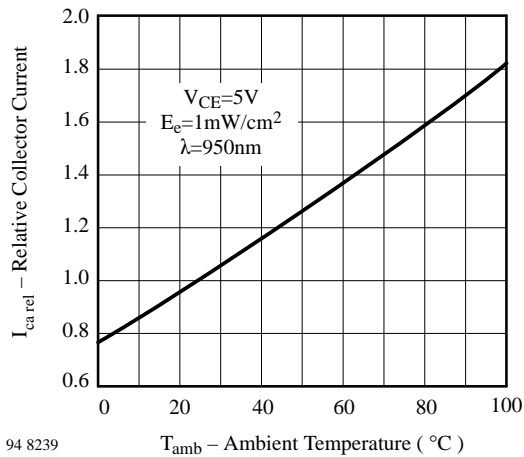

Figure 3 : Relative Collector Current vs. Ambient Temperature

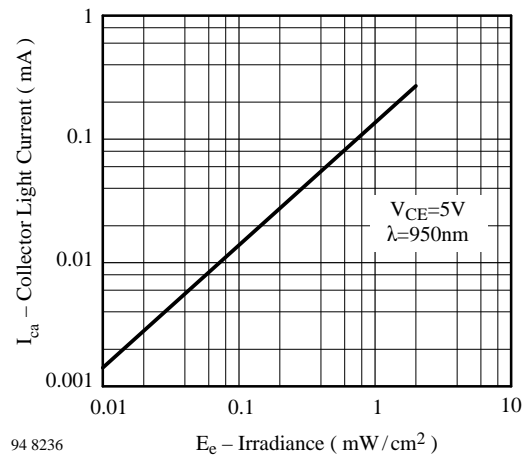

Figure 4 : Collector Light Current vs. Irradiance

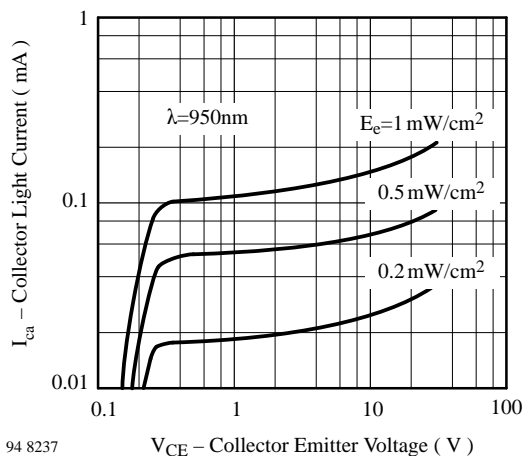

Figure 5 : Collector Light Current vs. Collector Emitter Voltage

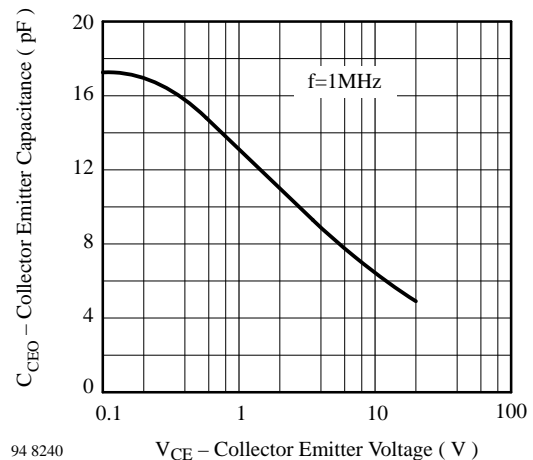

Figure 6 : Collector Emitter Capacitance vs. Collector Emitter Voltage

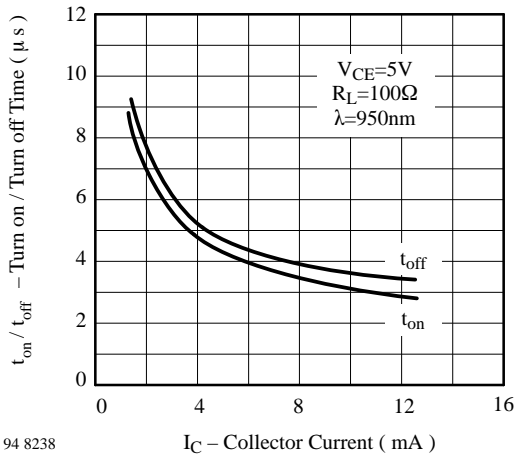

Figure 7 : Turn On/Turn Off Time vs. Collector Current

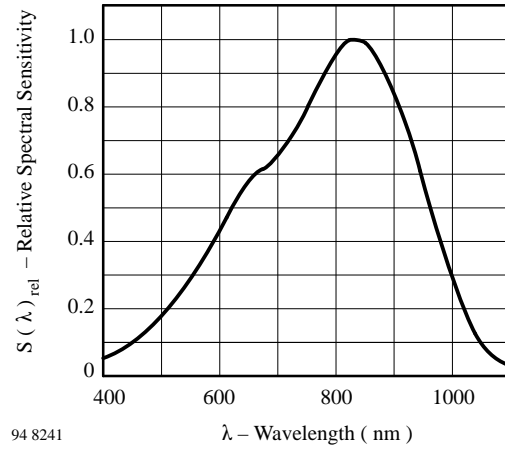

Figure 8 : Relative Spectral Sensitivity vs. Wavelength

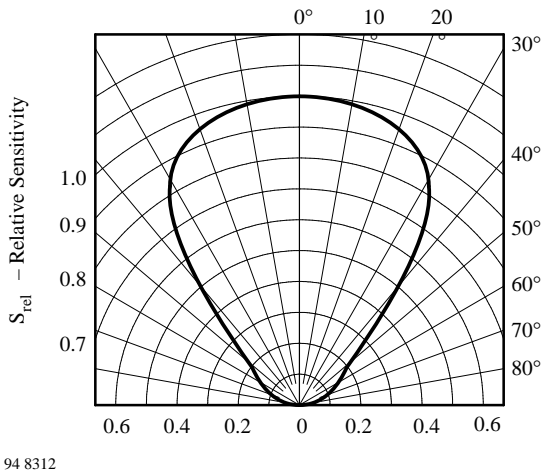
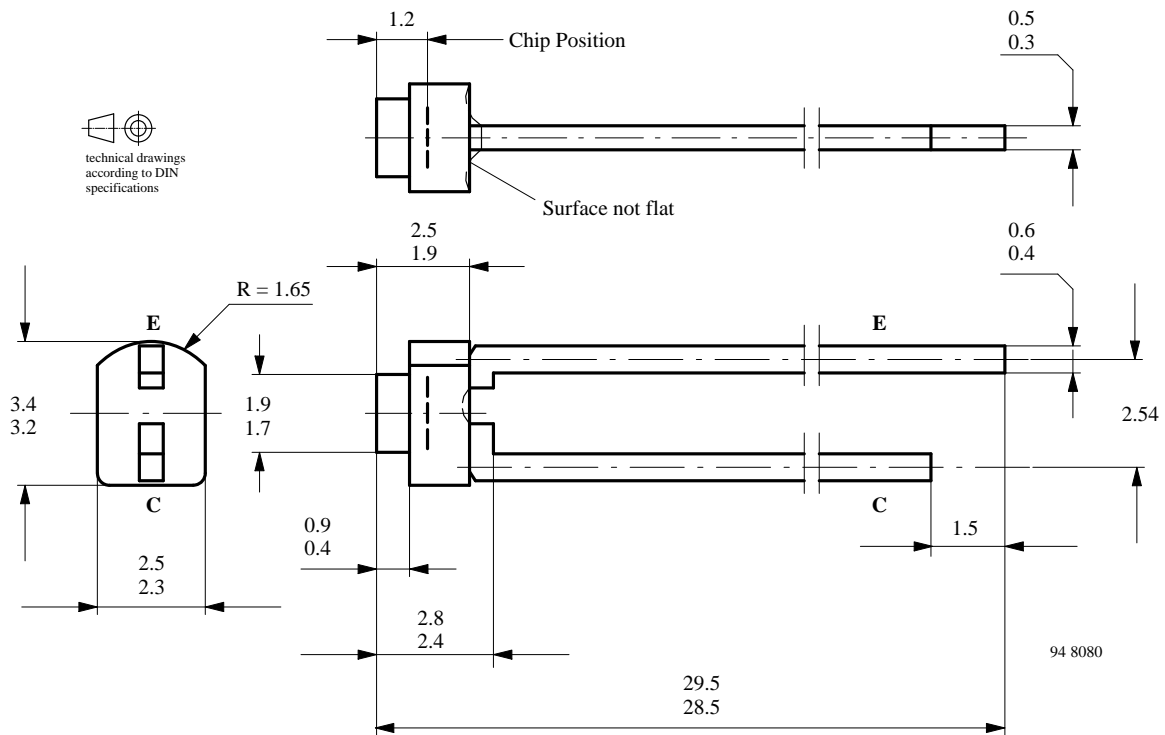

Figure 9 : Relative Radiant Sensitivity vs. Angular Displacement

## Dimensions in mm



**We reserve the right to make changes to improve technical design without further notice.**

Parameters can vary in different applications. All operating parameters must be validated for each customer application by the customer. Should the buyer use TEMIC products for any unintended or unauthorized application, the buyer shall indemnify TEMIC against all claims, costs, damages, and expenses, arising out of, directly or indirectly, any claim of personal damage, injury or death associated with such unintended or unauthorized use.

TEMIC TELEFUNKEN microelectronic GmbH, P.O.B. 3535, D-74025 Heilbronn, Germany  
 Telephone: 49 (0)7131 67 2831, Fax Number: 49 (0)7131 67 2423